

The following article was offered on the 'net to assist owner-operators of certified aircraft (notably Pipers) live in harmony with their electrical systems. There is much information that is accurate but some important points that are not accurate. Further, the trouble shooting procedures do not first look at most probable causes with diagnostic measurements of major components. If major components are not implicated, then one should "divide and conquer"; halve and then quarter the field of investigation to narrow down the search for a faulty connection. But most of what is suggested as possible/probable cause for investigation practically never happens.

I have no doubt that the author would do a good job fixing his airplane and he put a lot of work into crafting this piece. However, the procedures cited would not be very useful to the neophyte technician. The article was downloaded from <http://www.nflite.com/ChargingSystem.html> on February 10, 2008

Robert L. Nuckolls, III  
11 February, 2008

We wish to thank Mr. Adkins and the Piper Owners Magazine for permission to reprint this fine article on aircraft electrical charging systems. It will help you gain a general working knowledge of this rather simple but often neglected and abused system. With this knowledge you can avoid costly maintenance and troublesome failures.

-----\*\*\*\*\*-----

Know Your Charging System

By Robert M. Adkins

Light aircraft charging systems are similar to their automotive and marine counterparts, and are quite simple in nature. There are a couple of notable differences, however.

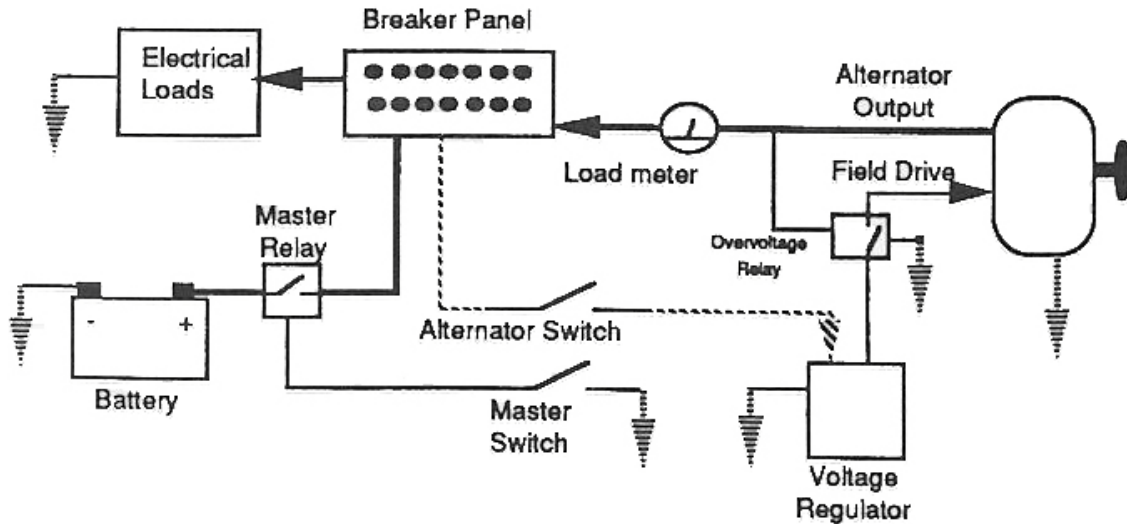

Figure 1, Cherokee (typical) aircraft electrical system

Unlike a car or boat, an aircraft electrical system is controlled by a separate switch (the master), not the engine ignition switch. In addition to the battery master switch, a separate switch is provided to allow the charging system of an aircraft to be shut down while still leaving the battery on. This separate switch is the cause of the majority of the problems and the short life expectancy (high failure rate) of light aircraft charging systems. There really is little difference in all of the other parts of the charging system, mechanically. Electrically, an alternator that is used in an aircraft should last just as long, if not longer, than the same alternator used in a car or boat.

If you have doubts about the statement just made, read on. I think by the end of this article you will find substantial justification for that statement, as well as proven suggestions that you can use in virtually any single engine or light-twin aircraft to substantially extend the life expectancy of your charging system. This might just bring a little more peace of mind the next time you find yourself in heavy IFR at night near freezing level, not to mention the savings in maintenance costs.

I will explain the function of each of the major components found in aircraft (and most all) charging systems. I will also describe the most common failure of each of the individual components and the symptoms that may be observed. In addition, I will show some basic

troubleshooting tips for several of the most common charging system failures and the likely causes for each.

Please note that I have taken great care to arrange the troubleshooting and parts list in a logical and cost effective order. You may chuckle a little when I suggest that you verify the operation of a switch, circuit breaker or connection, but these checks take very little time and effort to perform and will not cost you anything. These components do play major roles in the charging system. We may not want to admit it, but a lowly switch, circuit breaker or connection can completely disable a charging system. If you don't believe me, you might want to read the tale of David and Goliath -- and ask Murphy his opinion, while you're at it.

Anyway, if a problem is found with one of these components, they will be the least expensive to replace. And I assure you that they do fail, especially in older aircraft or those exposed to damp or corrosive environments. If after checking all of these basic parts you conclude that the problem is elsewhere, at least you will feel a bit more confident about dropping \$100-\$300 on voltage regulators and alternators.

#### The Major Components

Aircraft charging systems consist of the following major components:

- Alternator
- Battery
- Voltage regulator
- Over voltage relay
- Battery master switch
- Master relay
- Alternator master switch
- Alternator field breaker
- Alternator output breaker

The components of most light aircraft charging and starting systems carry the same brand names as automotive models, and they appear to be the same. Are they any different, or are they just automotive parts sold at inflated prices? The answer is neither, Yes, they do appear to be the same from an outside look, and many of the internal components are the same. Yet there are many differences, and unless you know what they are for your particular part, do not substitute automotive parts. Brushes, for example, have different mechanical and electrical specifications. In some alternators, the cooling fins are backward compared to their automotive counterpart. Don't gamble that what looks alike IS alike.

***Not sure of the significance of this last statement. If we're talking about certified aircraft then the only legal replacement for any part of the airplane is what's called out in the service parts catalog. It matters not what visual similarities the part has with a non-approved part of any brand.***

The alternator is the business end of the charging system. Alternators typically produce their rated output power at 5,000-6,000 RPM. In automotive applications, the alternator drive is usually reduced 2 to 1

to achieve optimum power output at typical cruise speed RPM's. In an aircraft installation, the drive ratio is typically 3 or 4 to 1. For this discussion I will assume that the alternator is always turning at the optimum RPM which would at any time allow it to produce its maximum rated power output.

*I think the author means that the alternator is turning about 2x crank speed in cars such that for 2500 rpm cruise on the highway, the alternator is running about 5000 rpm . . . fast enough to carry rated loads. If the ratio on aircraft is 3x to 4x, then at 2400 rpm on the crank, the alternator will be running at 7200 to 9600 rpm. This is a wide span of speeds which speak more to "adequate" than "optimum".*

#### Alternator and Battery

An alternator consists of three basic components: rotor stator rectifier. The rotor and stator are windings made up of varnished copper wires; the varnish acts as an insulator. The rectifier is made up of six diodes, arranged in pairs. Each pair of diodes rectifies the current from each of the fixed phase windings in the stator.

Most alternators do not have fixed magnets, and therefore do not produce any power on their own. In effect, an alternator is a form of power amplifier; it can turn a small amount of electrical power into a large amount of electrical power by using mechanical force (the engine drive).

*Perhaps "energy converter" is a better term as opposed to "amplifier". Alternators convert mechanical energy into electrical energy and there there is no "amplification". In fact, the alternator is probably on the order of 60-70% efficient . . . meaning that a portion of the input energy is tossed off as heat. I.e, output power is less than input power.*

An alternator requires a small amount of external power to produce a magnetic field in the windings of the rotor. The strength of this magnetic field determines the amount of power (current) that may be sourced from the stator windings. The strength of the magnetic field produced by the rotor is controlled by controlling the amount of current that it draws. Most rotor field windings can draw up to 4 amps. The output of the stator windings is three phase AC. A three phase, full wave diode rectifier (two diodes per phase) rectifies the AC voltage produced by each winding of the stator to useable DC voltage.

*In this sense, one might consider the wiggling of a field winding at up to 14v and 3A (42 watts) has control of as much as 14V at 100A (1400) watts to be a manifestation of "gain" . . . but then a vacuum tube can be said to have power gains of perhaps 1000 or more. Nonetheless, for total power in versus usable power out, both alternators and vacuum tubes are much less than 100% efficient.*

The battery plays two main roles:

- 1) It supplies current to the rotor field windings to produce a magnetic field.

*Sorta . . . many alternators require external excitation (usually ship's battery) to come on line but once "started" the alternator does not depend on the battery for continued operation. I.e., once on line the alternator supplies its own field power.*

- 2) It acts as a capacitor to both draw and smooth the rectified power (current) from the stator of the alternator.

*I used to think that too . . . you know, it sorta made intuitive sense; the battery is a huge energy source as a supply or energy sink as a storage device. One can easily morph these facts into some notion of batteries offering a kind of electrochemical inertia that tends to smooth small perturbations in bus voltage.*

*Consider this: A battery becomes a source of energy at 12.5 volts and below. It becomes a sink of energy at 13.8 volts and above. There is a span of about 1.3 volts where the battery is neither an effective sink nor source of energy. Any wiggles of bus voltage that venture into this range are essentially unaffected. The whole idea of the battery being any sort of "filter" falls apart. In fact, put your oscilloscope on the bus of any automobile with the engine running. Note the bus noise with the battery connected. Disconnect the battery. The engine continues to run and the noise on the bus doesn't change much.*

Alternators are generally very reliable. They do, however, have one main enemy -- heat. Overheating or overloading an alternator may melt the varnish insulating the copper wire in the field windings of the stator very quickly. It also weakens the diodes that make up the rectifier.

*Yeahhhhh . . . sorta. "Over heating" is a function of defective installation. Every alternator is qualified to carry its rated loads indefinitely. Every approved alternator installation is required to demonstrate its rated performance under worst case conditions: Hot day, max angle climb and electrical load equal to the rating of the alternator.*

*Of course it's perfectly legal to "de-rate" an alternator. If you've got a 60A alternator installed in a C-150 that never needs more than 30A and cooling is insufficient for 60A loads, then all one has to do is change the nameplate rating on the alternator to 30A, run the loaded cooling tests at 30A and call it "golden."*

*But if the airplane's documents claim a 60A alternator, then the folks who qualified the alternator onto that airframe were obligated to demonstrate it. The notion that diodes or varnish somehow can fall prey to mishandling by the operator is simply not demonstrable. These issues are not something that the owner operator should even be aware of much less concerned about.*

With the exception of the bearings that support the rotor, the field brushes are the only other part that is subject to wear. The brushes are not actually a brush but rather a precisely machined piece of carbon with an imbedded wire which is quite fragile. The brushes make contact with the rotor ring to supply current to the field windings. Each brush is held in contact with the rotor ring with a spring. Carbon dust that accumulates as a brush wears can cause it to stick in place; eventually the brush will not make contact with the rotor ring.

***Everybody I know calls them "brushes" and "slip rings". Don't know about "fragile" . . . they are indeed much smaller than the brushes that would be found in a 60A generator . . . but I would not call them "fragile".***

Voltage Regulator and Over voltage Relay

The purpose of the voltage regulator is to maintain the electrical system voltage to a preset level. The voltage regulator performs this function by controlling the amount of current that is sourced to the alternator field windings in the rotor. This device may be a mechanical relay type unit or a solid state transistorized unit. Either type performs basically the same function. Most 12 volt system regulators are set to maintain the electrical system voltage at 13.8 volts.

***13.8 is the "magic" voltage required to top off a battery to 100% of full capacity at room temperature . . . provided that you're willing to wait quite awhile. The majority of the regulators I've cross paths with were factory adjusted for 14.2 to 14.6 volts . . . a slight but sufficient "over charge" intended to meet design goals for recharging a dead battery in something on the order of 60 to 90 minutes of flight. Put a voltmeter on your car battery with the engine running, I think you're going to see 14.2 volts or more.***

Voltage regulators accomplish this task by controlling the current that is sourced to the alternator field windings in the rotor windings, as well as the amount of power that is generated by the alternator stator windings. This is the only function of a voltage regulator. Solid state voltage regulators respond faster and more accurately to loads on the electrical system than do the mechanical types, and have the benefit of no moving parts to wear out. There are, however, two distinct differences in the way these units may fail.

***"Faster and more accurate" are not quantified . . . the two technologies offer essentially the same electrical performance. However, the electro-mechanical devices are decidedly limited in service life and much more vulnerable to environmental extremes.***

Mechanical (relay type) voltage regulators almost always fail open circuit, either because a relay coil or a resistor burns out. In very rare cases, the relay contacts may weld closed. Solid state voltage regulators tend to be of the 50-50 type failure; sometimes they short

circuit and sometimes they open circuit. As I have found more short circuit failures than open circuit failures, I tend to lean toward the possibility of a short circuit failure on solid state voltage regulators.

Q. What happens when a voltage regulator of either type fails with an open circuit?

A. No current can be sourced to the rotor field windings, which turns off the magnetic field and the stator windings produce no power.

Q. What happens when a voltage regulator fails with a short circuit?

A. Assuming that this is not a catastrophic internal failure which would cause the alternator field circuit breaker to trip, the field windings would be able to draw the maximum possible current and would effectively turn the alternator full on. In this condition, the alternator is producing its maximum rated power. You might think that this is not a problem, but due to rules governing inductors and capacitors an even bigger problem will develop: runaway output voltage. If there is not sufficient electrical load to use all of the available power from the alternator, the voltage in the alternator stator windings will rise uncontrollably.

*Not sure about the reference to "inductors and capacitors" . . . but yes, a runaway is an uncontrolled rise in output voltage. In practice, this condition is mitigated only by system loads and how much abuse the battery can accept before the OV protection system reacts and shuts the alternator down.*

*From the onset of the OV condition until the OV protection shuts the alternator off is under 100 milliseconds. During this time, the battery prevents the bus voltage from rising as fast as the alternator would drive it were the battery not present. A lightly loaded 60A alternator will push a good battery up to 17 volts or so during the first 100 milliseconds of the event which is plenty of time for the OV relay to react.*

*If the battery were not present, the industry assumption is that 14v bus could rise to as much as 40 volts but for no more than 100 milliseconds before the OV system brings the failure to heel.*

Both of these failures are a problem. The second failure, however, could do potential damage to the radios and other appliances in the electrical system. This is the purpose of that sometimes mystical and poorly understood over voltage relay. This relay will open the alternator field drive circuit when the voltage in the electrical system rises above a preset point. In 12 volt systems, this is usually 15-18 volts.

*Every customer I've serviced for the design of OV protection has asked for a trip point of 16.2 to 16.5 volts in 14V systems and 32.5 to 33.0 volts in 28V systems.*

The over voltage relay does not cut off the alternator output, instead it cuts off the alternator field drive which effectively turns the alternator off. This device is usually a non-resetting relay. As soon as the over voltage relay opens the field drive and the alternator is turned off, the electrical voltage will drop back to about 12 volts. The field voltage, however, is not re-activated. Otherwise, the electrical system would oscillate in a high-low-high-low voltage condition. In order to reset an over voltage relay the alternator (or master) switch must be turned off for a few seconds and then turned back on.

By the way, you might find it interesting to know that most automobiles do not have an over voltage relay. Auto manufacturers don't think that an over voltage condition is very likely to occur in a car. However, when it does it usually burns out all of the lights. Most other components - fans, heating elements, etc.- will survive.

#### Battery Master Switch and Battery Master Relay

The master switch is usually two switches in one. The left side controls the battery by turning the electrical system on and off and the right side controls the alternator. The battery must be turned on in order for the alternator to be turned on. Turning on only the alternator side will do nothing.

***This is an attempt to describe the split-rocker DC power master switch used on many single-engine light aircraft. It's almost correct. The battery side can be turned on without having the alternator on but any attempt to turn on only the alternator will result in BOTH systems being turned on. Conversely, one can turn the alternator off without turning the battery off but any attempt to turn the battery off by itself will take the alternator off too.***

There is one very important distinction that should be made: The alternator switch turns the voltage regulator on and off, not the alternator output. The voltage to the alternator switch comes from the alternator field circuit breaker, which is tied directly to the aircraft battery through the master switch.

The battery master switch handles very little current. It is usually less than 0.5 amps -- the current it takes to drive the master relay coil. The master relay handles all of the electrical load. This includes the engine starter, which amounts to 200-400 amps when starting the engine and 30-70 amps under normal operating conditions.

***A bit misleading. Yes, before the engine starts, all equipment turned on gets power through the battery master contactor. When the engine is cranked, that power comes through the battery master relay. After the engine starts and the alternator begins to produce power, energy flows back into the battery to replace that which was withdrawn before the engine starts. The alternator and not the battery/battery master contactor carries system loads.***



The alternator side of the master switch is a different story. This switch handles all of the alternator field drive current -- usually around 2-5 amps. This is a significantly higher load on the switch, yet this switch has a fundamentally more significant role than the battery side of the switch. The condition of the contacts (the contact resistance) in the alternator switch will affect the voltage that the voltage regulator will see.

This is where Ohm's Law starts to have an affect, and this is where just about everyone seems to get lost and misinterprets the symptoms. Using Ohm's Law we can calculate the voltage drop across a resistor based on specific current. So what does this have to do with a switch? Plenty. If I could have a dime for every voltage regulator that was mistakenly replaced because of this switch, I would be a very rich man. As the switch degrades due to oxidation of the contacts caused by internal arcing when it is switch on and off, the contact resistance increases.

Say, for example, the switch has developed 0.5 ohms of resistance (which is very small) and the maximum current required to drive the alternator field is 4 amps. What voltage would be detected at the voltage regulator?

$$V \text{ drop} = 4 \times 0.5 = 2 \text{ volts}$$

$$V \text{ reg} = 12 \text{ volts} - 2 \text{ volts}$$

$$V \text{ reg} = 10 \text{ volts}$$

While this V reg is not strictly accurate, the voltage drop across the alternator switch is. This means that the voltage regulator will see 2 volts less than the rest of the electrical system when 4 amps are flowing to the alternator field. A more accurate way of looking at this is to ask what voltage is the rest of the electrical system at. With the voltage regulator preset to maintain a 13.8 volt level, the rest of the system is at  $13.8 + 2 = 15.8$  volts while the regulator is seeing only 13.8 volts!

***An interesting hypothetical that pushes most if not all of the cause for "galloping ammeter" syndrome off onto the alternator side of the split-rocker switch. In fact, should this switch actually degrade to the point of adding 500 milliohms resistance to the voltage regulator's sense path, it would ALSO be dissipating 2 volts x 4 amps or 8 watts. This amount of heat dissipated in so small a feature would at least produce a smoking if not a flaming switch. The real case is not hypothetical. Most regulators will become unstable when total resistance between the bus and the regulator totals 200 milliohms. Further, that total is distributed across ALL of the joints in the pathway. Replacing a switch may produce the appearance of having "cured" the problem***

. . .

This insidious problem only gets worse as the resistance in the switch causes it to heat up and further degrade the contacts. You may be surprised to know that this same 0.5 ohms at 15.8 volts and 4 amps must dissipate 8 watts of power!! While this may not seem like much, we're talking about a device that is not designed to dissipate heat.

Most of the time when a switch gets this bad it starts to act like a Christmas tree. As the contacts heat up the metal warps and the contacts open. The contacts cool down and again make contact. The cycle repeats.

*Another interesting but unsupportable phenomenon. Failure in a switch with rising resistance does not present a cycling conduction pattern. See <http://tinyurl.com/2a2qqp> for an exemplar investigation of switch failure. In this case, the switch resistance probably did not exceed 100 milliohms but the 600 or so milliwatts of heating slowly cooked the switch's innards. In the mean time, the strobes kept right on working.*

The result is a charging system that is being turned on and off, just as if you were flipping the switch; which results in a fluctuating ammeter.

*The author is speaking about the "galloping ammeter" phenomenon that is common on many older light singles. It's a condition that manifests ONLY on voltage regulators where the alternator field power lead and bus voltage sensing share the same conductor. It's a correct statement that an increase in resistance between the bus and the voltage regulator is the driving condition. It's incorrect to lay the blame exclusively on the alternator control switch because in some aircraft, particularly older Cessnas, there are over a dozen joints in the current path between bus and regulator ALL of which increase with age and ALL of which contribute to the unstable voltage regulation phenomenon. It's easy to assume that all blame can be laid at the feet of the switch because replacing many switches has "fixed" the problem.*

*If the system went unstable at say 130 milliohms of total resistance and the switch was contributing say 30 milliohms of the total, then putting in a new 10 milliohm switch causes the oscillation to cease . . . but it comes back faster than from factory new. The REAL fix for the galloping ammeter is to replace or refurbish every piece of hardware in the circuit all the way from the bus to the regulator including the switch. Drive the total loop resistance down to factory new levels. This approach will cause the problem to go away for decades instead of years.*

*The still better solution is to simply replace the regulator with a device where field supply current and bus sensing duties are split between two separate wires I.e, separate remote voltage sense leads. Now, increases in loop resistance from bus to regulator in the field supply line no longer interact with the voltage regulator functions and the condition NEVER happens again.*

A second type of failure will also produce the same result. If the switch contact resistance increases significantly, the voltage regulator may not be able to flow sufficient current to the alternator field before the voltage drops below the point at which the voltage regulator will operate. When the voltage drops too low the voltage regulator turns off and stops flowing current to the alternator field. This allows the voltage level to return to normal, at which time the voltage regulator turns back on and the cycle repeats.

Once again you're flying a blinking charging system. Except, in this case, the rate at which the system turns on and off will usually be very rapid -- more than once a second.

I am frankly amazed at some of the bizarre suggestions I hear or read about on electrical systems on light aircraft. I have to say that I know some very competent aircraft mechanics whom I trust and respect very much when it comes to mechanical work. I wouldn't, however, let them wire the lights on a Christmas tree, let alone troubleshoot (at my expense) the electrical system on my aircraft.

***Not sure what the "second type of failure" is . . . increase in loop resistance for shared field supply and bus voltage sense paths is root cause of this phenomenon.***

#### Ammeter/Load Meter

Last but not least is the ammeter, sometime called the load meter. In some airplanes (and cars), the ammeter shows the charge and discharge state of the battery. In Cherokees the ammeter shows only the charging current (the alternator output). Under normal conditions this charging current is equal to the electrical load on the system, and this is why the ammeter in a Cherokee is sometimes called the load meter.

Keep in mind that the ammeter in the Cherokee only shows the output of the alternator. If the alternator is off line (turned off or broken), the load meter will read zero. There will, however, still be an electrical load that will continue to drain the battery unless the master switch is turned off.

#### The Charging System

Ok, so now you know what all the major components of the charging system are and how they function. Let's put it all together. Figure 1 shows the most typical aircraft electrical system, and is an accurate depiction of the electrical and charging systems in the Cherokee.

Note the dashed line between the breaker panel and the voltage regulator with the alternator switch in the middle. This line provides three functions: 1) Power for the voltage regulator's internal circuits. 2) Voltage sensing of the electrical system. 3) Power - via the voltage regulator, to the alternator field drive (rotor windings).

Poor connections in the line can wreak havoc with the charging system. Many hundreds of dollars have been spent replacing perfectly good voltage regulators, alternators, over voltage relays and who knows what else in an attempt to cure the fluctuating output problem. 99% of the

time it is a problem in this line. Most of the time it is simply a faulty or worn out alternator switch -- typically a \$10 part.

***A recap of the phenomenon described above and yes, the switch is a contributor but the first time this problem is encountered, all the parts including breaker, switch, terminals and pins in connectors should be replaced. Every CONNECTION that carries this current except the wires and appliances themselves. This drives the total resistance back down to what it was when the airplane left the factory.***

If there is a problem in this line that limits the current that can be drawn by the voltage regulator (and the alternator field drive), several things will happen. When the voltage regulator senses a low voltage condition it attempts to source more current to the alternator field. The more current that flows through this line the greater the voltage drop that occurs. The more the voltage drops in the line the more the voltage regulator attempts to source to the alternator field.

This vicious cycle continues until either the alternator is turned on full, potentially causing an over voltage or the voltage drops so low that the voltage regulator can no longer function and shuts down. As soon as the voltage regulator shuts down the current flow to the alternator stops and the voltage on the line increases. When the voltage increases enough to operate the voltage regulator the cycle repeats. The pilot sees a rapidly fluctuating (usually more than once a second) amp/load meter, as the system turns on and off like a Christmas tree bulb.

It's not quite that serious. Yeah, the voltage wiggles around perhaps 1 volt peak-to-peak and the ammeter dances and the panel lights flash in unison . . . but if addressed soon after onset, it's not going to hurt anything.

The first thing most mechanics will do is to take the system apart, suspecting a faulty alternator or voltage regulator. Unfortunately, this is the beginning of an expensive route to failure. Why suspect a faulty switch or circuit breaker, Few people stop to realize the thousands of times that the master switch is turned on and off in the lifetime of an aircraft. Each time that the switch is turned on or off a small amount of internal arcing occurs. This arcing degrades the metal in the switch contacts and increases the resistance across the contacts.

This usually does not cause a problem for the battery side of the master, since the actual current is carried by a remote master relay. The increased resistance across the alternator portion of the switch will, however, cause problems. A contact resistance of a mere 1 ohm will cause havoc. As the voltage regulator attempts to source more current to the alternator field the 1 ohm resistance in the switch (or anywhere in the line) will cause the voltage to drop one volt for every one amp of current drawn by the voltage regulator. This causes the voltage regulator to source more field drive current than is required to maintain the correct system voltage level. In the early stages of this problem there may be a tendency to overcharge the battery and increase the overall electrical system voltage. Or it may even cause

the over voltage relay to trip, leading to the incorrect suspicion of a failed, or failing, voltage regulator.

The output of the alternator goes to the alternator output breaker and is connected to the aircraft electrical bus. The ammeter is placed between the alternator output and the circuit breaker to show the current flow into the aircraft electrical bus.

That is all there is to the Cherokee charging system. It is really quite simple. The charging system design on the Cherokee is virtually identical to most other charging systems in light aircraft. As simple as these charging systems are, the problems that occur are often blown way out of proportion. I have watched qualified mechanics laboriously take apart an electrical system before they even checked to make sure the alternator field circuit breaker was working.

***The term "qualified" is suspect. Yes, it's quite common for mechanics, pilots and owners alike to trouble-shoot by swapping in new parts until the problem goes away. None of these individuals is capable of doing the job with a minimum expenditure of \$time\$.***

Of course the airplane owner is paying for their time and the parts. I have also heard the war stories from aircraft owners who troubleshoot and service their own planes. Most of these expenses can be chalked up to a misunderstanding of the charging and electrical system.

***Yup, the most expensive malady from which mankind suffers is ignorance.***

Making your charging system last

You may be surprised at the number of things that may turn on and off unexpectedly, causing a fluctuating ammeter, yet the charging system is working fine. In fact, it is doing the job it was designed to do. Rotating beacons that are near the end of their lives, some transponders, landing lights with bad connections, pitot tube heaters, landing gear systems, etc. can all turn on and off unexpectedly.

***Hmmmm . . . yes, when connections get loose or switches wear out there may well be conditions of intermittent operation. I'm mystified as to the point of bringing it up in this document.***

So you don't have any problems and hope you never will. Perhaps if you follow two simple suggestions you may never have a problem, or at least you will substantially reduce the chances of having one.

Have you ever asked yourself why the charging systems in aircraft fail so often? In reality they should last longer than their automotive counterparts. Why is that? Consider that the alternator in a car is subjected to far more engine starts (requiring a heavy charge at low RPM), and often has to sustain a heavy load during engine idle on hot days while you're stuck in traffic with the air conditioner running full blast. They have to operate in heat conditions that are well above 200 degrees F with poor ventilation. The alternator is usually mounted near the bottom of an engine and is subjected to repeated water drowning - complete with road grime and dirt, when driving in the rain.

Even subjected to all this abuse it easily survives 10 years and over 100,00 miles.

I can honestly say that I have never seen a Chrysler alternator fail electrically in any vehicle or marine application. The one in my 1964 Plymouth Valiant has over 200,000 miles on it. Ditto for the pickup and the station wagon. This is the identical 60 amp alternator installed on many Cherokees, the only difference being a little sticker that says FAA-PMA approved.

I have seen Chrysler alternators fail mechanically - the diode packs having fallen out or bearings seized - but not electrically. So why does everyone curse their Chrysler alternator? Probably because it was the alternator that was installed in the airplane. Talk to a Beech or Cessna owner and they probably don't have much good to say for Delco or Prestolite alternators either.

The alternator in an aircraft is operating in a nearly perfect environment -- relatively constant speed, constant load, low overall load, high RPM, a fairly cool well ventilated space, rarely gets wet, not exposed to much dirt and grime. But why do they fail so much more often, The primary reason is overloading. The secondary reason is simply the design of the charging systems in light aircraft. Often, the alternator and voltage regulator have not failed, it's simply a switch or circuit breaker that has become faulty. Why does this not happen in a car? Read on.

***The foregoing four paragraphs are a REALLY broad brush treatment of a very complex set of variables where correlation/cause/effect are exceedingly difficult to study and quantify.***

Don't overload the system!

You might say, I can't overload it. And I will say, "You do it every time you start your airplane". Yes, that's the sad truth and probably the main reason aircraft charging systems have such a high failure rate. Yet there is a very simple thing that you can do that does not require any modifications to your aircraft. The two simple steps are:

- 1) Leave the alternator switch OFF BEFORE starting the engine.
- 2) Turn the alternator switch ON AFTER the engine is running.

This same process occurs automatically when you start your car or boat or virtually any other machine with a charging system. This function is performed by the ignition switch in your car. Accessories will work with the ignition switch in the on position, but will cut out when the switch is advanced to the engine start position. The ignition switch is also cutting off power to the voltage regulator (which shuts down the alternator) while the engine is being started.

In an aircraft, the alternator is usually turned on at the same time the master switch is turned on. This applies full power to the alternator field, since the voltage regulator is sensing the battery voltage (which is less than 13.8 volts). You then start the engine

using the ignition switch. During the start, power is available to the alternator through the voltage regulator.

As the engine is being started the alternator is turning fast enough to produce some power. At the same time, however, the starter is drawing 200 to 300 amps. Most alternators can only sustain 60 to 70 amps -- 200 to 300 amps is equivalent to a dead short on the output of the alternator. This is a substantially overloaded situation, and the part most likely to fail will be the diode rectifier.

*There is no demonstration in the physics of how alternators work that will support this notion. The idea that an alternator can "overload" its own diodes during a startup transient when the engine is running slow and the diodes are cool is completely unsupported by fact. Diodes are specified to carry many times their rated current for short periods of time based on THERMAL considerations for being able to remove heat from the diode's junction. Further, an alternator is magnetically incapable of producing an output current transient that even meets much less exceeds the ratings of its companion diodes.*

*This article infers that improper operation of the alternator switch accounts for a perceived but un-quantified increase in incidence of failures for alternators in aircraft as opposed to automobiles. At the same time, no mention is made of the host of additional reasons that could explain the perception. I'll suggest that "certified antiquity" accounts for a lot of the perception. An alternator on a certified airframe is technologically frozen in time while alternators in automobiles evolve yearly.*

Listening to the radio:

Have you ever noticed how quickly the aircraft battery seems to run down when you are just sitting in the plane listening to the radio. All you have turned on is the master switch and one or two radios, and in an hour or so you end up with a low battery. Sure, the turn coordinator is running but electric gyros don't draw that much current, the radios certainly don't. Most radios draw less than 1 amp in the receive mode. If you have a typical 35 amp-hour battery, you should have plenty of reserve.

The one thing that is not being considered here is that usually when you turn on the master switch you turn on both sides of the switch (the battery master and the alternator field). So now the voltage regulator is on and sourcing up to 4-5 amps to the alternator field in a vain attempt to generate some power and raise the electrical system voltage to 13.8 volts. But that won't happen because the engine isn't running. So if you want to use the radio or other equipment, or any time you turn on the master - don't turn the alternator side on without the engine running! It won't accomplish anything except to drain the battery. And, if you subsequently start the engine, it will overload the alternator during engine startup.

*No, I've never noticed that . . . I don't sit in a parked airplane listening to the radio. Further, why would one even want*

**to close both the battery and alternator sides of the DC power master switch?**

Remember:

Engine stopped --- alternator switch OFF

Engine running --- alternator switch ON

**Yes, any truly qualified mechanic will conduct ground tests of electrical system components with only the battery side of the switch closed.**

Following these two simple steps will significantly increase the life expectancy of your aircraft's charging system, and you will not inadvertently run down the battery. Be sure to remember to turn on the alternator side of the master after engine startup!

**Whimsy not supported by the physics.**

We hope this has given you an enhanced understanding of your airplane's electrical system. The flashing light of the alternator LED on Nflite's EA-1040 Panel Annunciator will quickly remind you to turn on the alternator side of your split master once the engine is running. It will also call your attention to your battery master switch should you forget to turn it off after engine shutdown. Troubleshooting tips follow.

Troubleshooting tips:

Symptom: Battery not being charged at all -- no alternator output. 1) Check alternator drive belt for correct tension. 2) Verify that alternator switch is on. 3) Verify that alternator field breaker is not tripped. 4) Verify that alternator output breaker is not tripped. 5) Verify that alternator field drive has voltage. 6) Verify voltage regulator input voltage. 7) Verify that over voltage relay is not open. 8) Verify voltage at alternator field circuit breaker. Likely problems are: a) Open-circuit type voltage regulator failure. b) Faulty alternator field circuit breaker. c) Stuck or worn rotor brushes.

**Step (1) should be: Check bus voltage while the alternator is supposed to be operating. If the voltage is normal the battery is probably bad, not the alternator.**

**(2) If the voltage rises above battery-only levels, but still less than 14.2 to 14.6 volts, something in the regulator system is crippled.**

**(3) Step (5) should be step (1) . . . is there any voltage on the field of the alternator. If it's high (meaning that a regulator is full on and applying battery voltage to the field) and the alternator has no output, then check the b-lead. If it's reading battery voltage, then the alternator has failed. If it's reading 100 volts, then the b-lead circuit is open! If the field voltage**



***is zero, then something upstream in the field supply circuit has opened.***

Symptom: Some charging is occurring, but not enough to support electrical load -- battery dies after a short time. 1) Check alternator drive belt for correct tension. 2) Remove alternator and perform output power test. (Most automotive parts shops can safely perform this test.)

Likely problems are: a) Loose or worn drive belt. b) Partially failed diode rectifier (one or two phases.)

Symptom: Alternator shows substantial charge rate and then trips off - - alternator output breaker does not trip. Upon resetting the master (or alternator) substantial charge is indicated and alternator trips off.

Likely problems are: a) Short-circuit type voltage regulator failure. b) Faulty alternator switch. c) Faulty alternator field circuit breaker or connection.

Symptom: Alternator output fluctuating one or more times a second. 1) Check alternator drive belt for correct tension. 2) Verify that no heavy loads are being switched on and off (such as landing gear retraction motor, landing/nav lights, pitot heat, etc). 3) Verify all connections between alternator field circuit breaker and alternator field drive connections. 4) Check rotor brushes if fluctuations are very rapid and vary with engine RPM.

Likely problems: a) Faulty alternator field circuit breaker. b) Loose or bad connections between alternator field circuit breaker and alternator field drive connections at the alternator. c) Faulty/intermittent over voltage relay. d) Faulty voltage regulator.

Symptom: Alternator output fluctuating once every few seconds. 1) If retractable, verify that high pressure accumulator is not leaking; this causes hydraulic pump to activate every few seconds to keep gear up. 2) Verify that no heavy loads are being switched on and off (such as landing gear retraction motor, landing/nav lights, pitot heat, etc). 3) Verify all connections between alternator field circuit breaker and alternator field drive connections. 4) Remove alternator and perform output power test. Most automotive parts shops can safely perform this test.

Likely problems are: a) Heavy loads switching on and off. b) Partially failed diode rectifier (temperature sensitive). c) Faulty over voltage relay. d) Loose connections between alternator circuit breaker and alternator field drive connections. e) Fault alternator output circuit breaker. f) Loose or bad connections between alternator output and alternator output circuit breaker.

The above steps should be performed in the order shown in order to examine the simplest items first. Keep in mind that simple parts can and do fail. In fact, if your airplane is more than ten years old or has more than 2,000 hours I would suspect switches and circuit breakers before any active components. Switches and breakers that are old sometime just fall apart internally.

## Finding the problem

So now that you have all of this wonderful information, how can you check your charging system? Actually you can check out 80% of the system quite easily with one piece of common test equipment: a hand held voltmeter (VOM).

### ***Right ON!***

All the measurements can be made without the engine running, just with both sides of the master switch on. When the engine is not running the alternator is not producing any output, therefore to test the alternator output I recommend that it be removed and bench tested. This is the most effective method for troubleshooting the alternator. As this requires a significant amount of work on most aircraft, I recommend that you perform as much testing as possible with the alternator in place.

Since a voltage regulator is set to maintain the electrical system voltage at a higher level than can be produced by the battery when the electrical system is on (both master and alternator switched on) and the engine is not running, the charging system is fooled into thinking that a low voltage is present. As a result the voltage regulator will usually be turned full on, sourcing the maximum current to the alternator rotor field. This condition will benefit your troubleshooting efforts since it represents the worst case scenario of maximum charge rate (if the engine were running).

Check the battery: Before measuring any voltages first make sure that the aircraft battery has been fully charged, has the correct amount of fluid in each of the cells, and has clean and properly secured battery posts. To measure the voltages at the various points in the charging system connect your VOM's negative (black) lead to a secure ground point on the airframe. This point should be a structural member where connection to bare metal can be found, as it is usually not practical to connect directly to the negative post of the battery (though that is best).

Everything is relative, establish a reference: The first step is to measure the reference voltage to which you will compare all of your other measured voltages. With the electrical system on, measure and record the voltage on the buss bar behind the circuit breaker panel. All of the circuit breakers are usually mounted on one leg of this bar. This voltage will be your reference voltage and should be 12 (or 24) volts, plus or minus 0.5 volts. If this voltage is too low there may be a problem with the battery or master switch.

Check the voltage regulator sense line: Measure the voltages of all the connections in the line between the alternator field circuit breaker and the voltage regulator. The measured voltages should be plus or minus 0.1 volt of your reference voltage. If a lower voltage is measured, check the part and/or connection in question. For instance, if you measure 12.0 volts at the input side of the alternator switch and 11.2 at the output side there is no question that the switch is faulty and should be replaced.

Verify that the voltage regulator is properly grounded: Once the voltages on the line that feeds the voltage regulator have been measured the next step is to verify that the voltage regulator is properly grounded. This step is usually overlooked. An improperly grounded voltage regulator will have you chasing a flock of wild geese.

Checking the grounding of an electronic voltage regulator is simple. With the electrical and charging system on and you VOM negative lead connected to a secure ground, measure the voltage between the case of the voltage regulator and ground. If you get any measurable voltage the regulator is not properly grounded. For the old mechanical style regulators select the ohms (R x 1 if your meter has it) scale and measure the resistance between the case of the regulator and the airframe; there should be no resistance. Be sure to check that the regulator is properly secured and there are no loose screws.

Check the alternator field drive: The next task is to measure the voltage from the regulator to the alternator field. The engine should not be running. Measure the output voltage from the regulator being careful not to short the regulator output to the airframe -- this will destroy the regulator. The output voltage should be approximately one volt less than the input voltage. If there is no output voltage the regulator is no good. If the output voltage is very low (only 1 to 5 volts) the regulator is marginal and should be bench tested.

Next, measure the voltage at the alternator field connection. There is usually only one wire running to the field of the alternator. The other side of the alternator is usually grounded to the case. The large wire on the alternator is the output line. Measure the voltage on the small wire going to the alternator field being careful not to ground the field drive line. This voltage should be within 0.1 volt of the output voltage measured at the regulator. If the alternator field drive voltage is low a faulty line or connection should be suspected.

Check the alternator output: Measure the voltage at the output line of the alternator. This voltage should be within 0.1 volts of the reference voltage measured at the buss bar. If this voltage is low a faulty line or connections or circuit breaker should be suspected.

When everything checks out ok, but isn't: There are bound to be those systems that check out perfectly when measuring all of the voltages but still don't work right. In these cases I recommend taking the time to remove the alternator and have it bench tested. Once this test has been performed satisfactorily you have eliminated one of the three active components in your system (and usually the most expensive) from being the cause of the problem. The last two remaining active components are the voltage regulator and the over voltage relay.

Earlier we measured the input and output voltages without the engine running and were satisfied with the readings. Now we will perform the same measurements with the engine running. Secure the aircraft to a tie down and set the brake. Connect your VOM negative lead to a secure ground (airframe) and the positive lead to the voltage regulator input. Start the engine and set it to about 800 RPM. Note the voltage reading; if it is 13.8 to 14.2 and is steady your first step is

complete. Now measure the voltage at the main buss bar; verify that it is within 0.1 volts of the voltage reading at the input to the voltage regulator and is within the 13.8 to 14.2 range. If this is not true suspect a faulty connection between the buss bar and the voltage regulator input, most probably a high resistance connection or switch.

If your system is not charging but the alternator bench test checked out ok perform the following tests. Measure the voltage at the output side of the voltage regulator. Turn on the landing light and pitot heat; verify that the voltage regulator output voltage increases by more than 1 volt. Now measure the voltage at the input side of the voltage regulator; verify that the voltage is still in the 13.8 to 14.2 range. If not then suspect a faulty regulator.

If your alternator output is fluctuating check for fluctuating input voltage at the regulator. If the input voltage is going below 10 volts suspect a faulty regulator sense line, switches or connections. One way to verify a fluctuating charging system is to use small jumper lines and jump across the alternator circuit breaker (only temporarily for ground testing) and the alternator switch. If the fluctuation stops the problem is in the switch and/or circuit breaker. If the fluctuations don't stop when jumped make sure no loads are being switched on and off (as discussed earlier).

Finally, check the over voltage relay connections and grounding, being sure that the relay is properly grounded. Measure the voltage across the relay connections; reading should be 0. If there are more than 0.2 volts across the over voltage relay terminals, or it is fluctuating, considerate to be defective and replace it. Over voltage relays are generally reliable and inexpensive, but they do deteriorate with age.

*Most of the foregoing trouble-shooting advice is accurate. The test procedures go into a lot of detail for making checks on exceedingly low-probability failures and doesn't zero-in on the high-probability failures first. The procedures are reminiscent of the three column symptom/cause/remedy documents I used to craft in Cessna service manuals thinking I was doing a good thing. This article goes directly to my oft stated assertion that such literary hand-holding is not a substitute for understanding.*

*A truly qualified technician with voltmeter in hand will know exactly what device needs attention in minutes (or has divided the field of investigation down to what quarter or eighth of the system in which the faulty connection is situated). Further, the only reason to take anything off the airplane for performance testing is because the technician lacks tools, understanding or both to make the determination. A truly qualified technician knows exactly what needs replacing before turning a wrench.*

*I'll suggest that the perception of high failure rates on alternators has more to do with chronological age of the hardware, low usage (a happy machine gets used and tended to every day) and its antiquated design. The notion that an owner/operator can modify his/her behaviors to improve on service life of electrical system components is completely unsupported by the physics.*

*The equipment installed on a TC aircraft is qualified to the nameplate ratings. Further, as long as there is a battery on line, there is no manipulation of the alternator switch that places the rest of the system at risk or poses any hazard or undue stress on the alternator. That's why the split rocker switch was crafted to provide mechanical interlocking that prevents an alternator from being on line independently of the battery.*

*Finally, there are features of this article that are not terribly useful to the OBAM aircraft builder both because of the differences in 1970 versus 2000 architectures and the prevalence of internally regulated alternators on OBAM aircraft.*

Thanks again to Mr. Robert M. Adkins for permission to reprint this fine article. I hope it has been to of help you in both better understanding your aircraft's charging system and in troubleshooting those gremlins.

-----\*\*\*\*\*-----