

AEROELECTRIC CONNECTION

6936 BAINBRIDGE ROAD

WICHITA, KS 67226-1008

PHONE (316) 685-8617

Kit Contents: Numbers in [brackets] refer to item numbers on assembly drawing.

- 1 EA .1 uF CAPACITOR [6]
- 2 EA 20 uF OR 10 uF/35 V ELECTROLYTIC CAPACITORS [16 & 17]
- 1 EA 160 OHM RESISTOR [10]
- 1 EA 360 OHM RESISTOR (14-VOLT) OR 560 OHM RESISTOR (28-VOLT) [7]
- 1 EA LM317K INTEGRATED CIRCUIT
- 1 EA 3 POSITION TERMINAL STRIP [2]
- 1 EA BRACKET [1]
- 1 EA HEATSINK
- 1 EA I.C. SOCKET [9]
- 2 EA 6-32 X .50" MACHINE SCREW [8]
- 1 EA 4-40 X .63" MACHINE SCREW [3]
- 1 EA 4-40 X .43" MACHINE SCREW [19]
- 1 EA 4-40 X .25" MACHINE SCREW [15]
- 2 EA SOLDER LUGS [4 & 14]
- 4 EA 4-40 X .25" HEX NUT [5, 13 & 18]
- 1 EA HEATSINK INSULATOR
- 1 EA 1000 OHM (14-VOLT) OR 2500 OHM (28-VOLT) MINIATURE POT WITH WIRES
- 1 EA KNOB
- 5 EA #6-RED SPADE TERMINALS
- 1 EA SMALL QUANTITY ELECTRONIC SOLDER

Assembly steps

- (1) Heat sink may have captive nuts hardware installed in mounting holes; remove with pliers. Drill heat sink mounting holes to .250". Carefully debur holes. Check i.c. socket mounting dimensions with existing holes in bracket; you may have to work on the smaller holes a tad with a rat-tailed file. Suggest you glue heat sink to bracket with contact cement and allow to dry before mounting remainder of parts - you're less likely to damage insulating washer and/or slide parts under the i.c. causing shorts.
- (2) Mount integrated circuit, heatsink, integrated circuit socket [9] and gray insulating washer using two (.50") 6-32 machine screws [8]. Heatsink goes on side opposite mounting flange on bracket.

Note

Gray insulating washer installs between the integrated circuit and the heatsink.

- (3) Mount terminal block [2] using two 4-40 screws [3, 19] and hex nuts [5, 18]. The lower screw [19] flange) is longer (.63") to provide ground wire connection in plastic airplanes. Install second nut [18] on extended

threads of screw [19]. Install solder lug [4] under nut [5]. Use tiny drop of "super glue" on threads under nut just before final tightening.

- (4) Remove three inboard terminal block screws. Wires will be soldered directly into threaded holes.

Note

Take care that wires do not extend too far into holes causing shorts to bracket beneath the terminal strip.

- (5) Install solder lug [14] in remaining #30 hole using 4-40 x .25" screw [16] and hex nut [13]. Use tiny drop of "super glue" on threads under nut just before final tightening. Be sure that solder lug points to 10 o'clock position approximately as shown.

- (6) Install resistors [7] and [10]. 160-ohm resistor at [10] (color bands brown-blue-brown), 360-ohm resistor at [7] (orange-blue-brown). 28-volt dimmers use 560-ohm resistor at [7] (green-blue-brown).

- (7) Install electrolytic capacitors [16, 17]. Observe polarity markings on capacitor body; minus (-) arrow points to lead which should be grounded.

- (8) Install 0.1 uF capacitor [6].

- (9) Cut and strip ends of 1-1/4" pieces of 22 AWG insulated wire. Install at [11] and [12].

- (10) The potentiometer shaft may be shortened as desired using large diagonal cutters or line-man's pliers. Use fine file to debur cut end before installing knob.

Note

The knob supplied with the kit may be one of two types: (1) it may attach with one or more set screws or (2) grip the shaft with a precision collet which is tightened by means of a screw under a removable gray plastic cover.

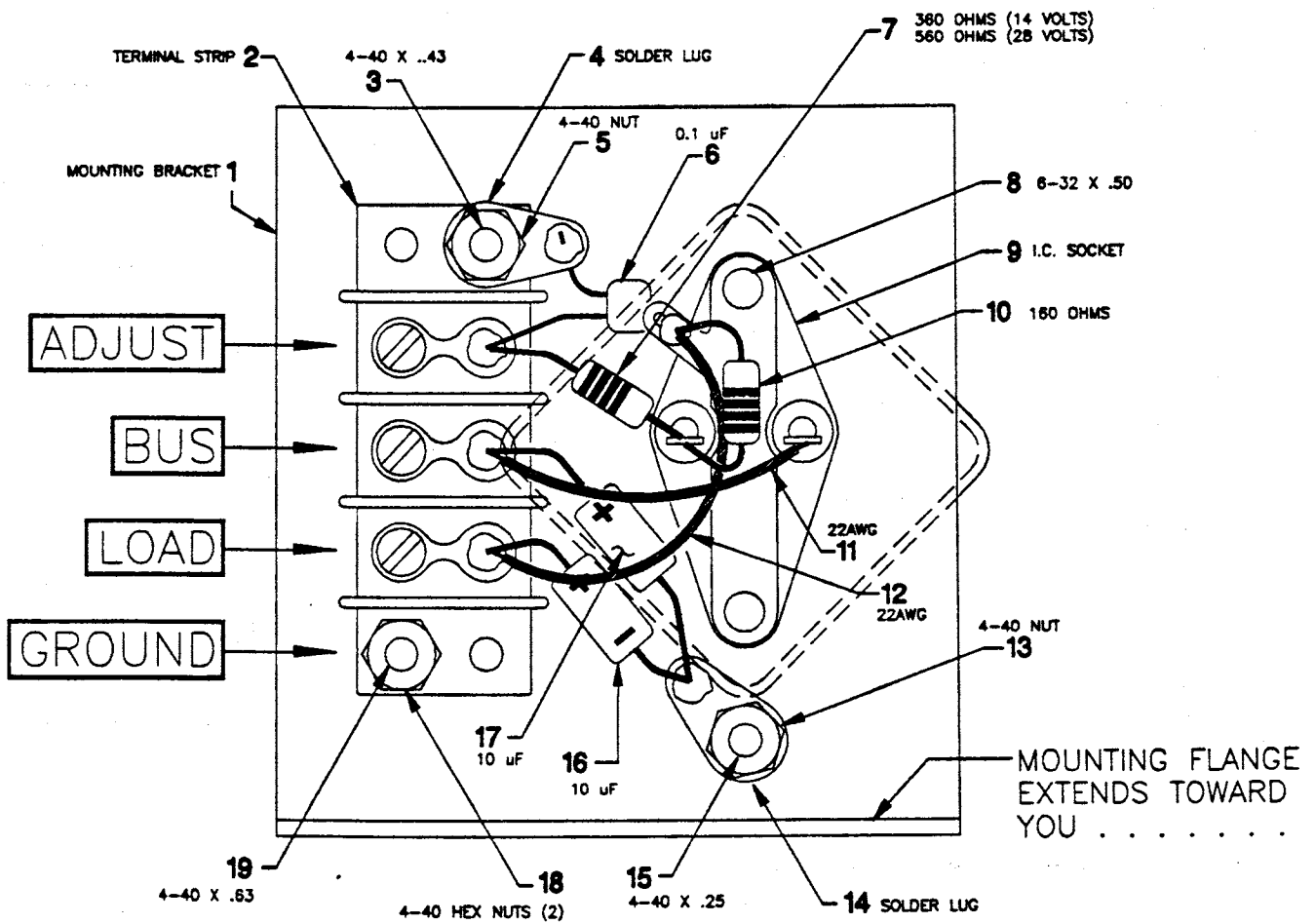
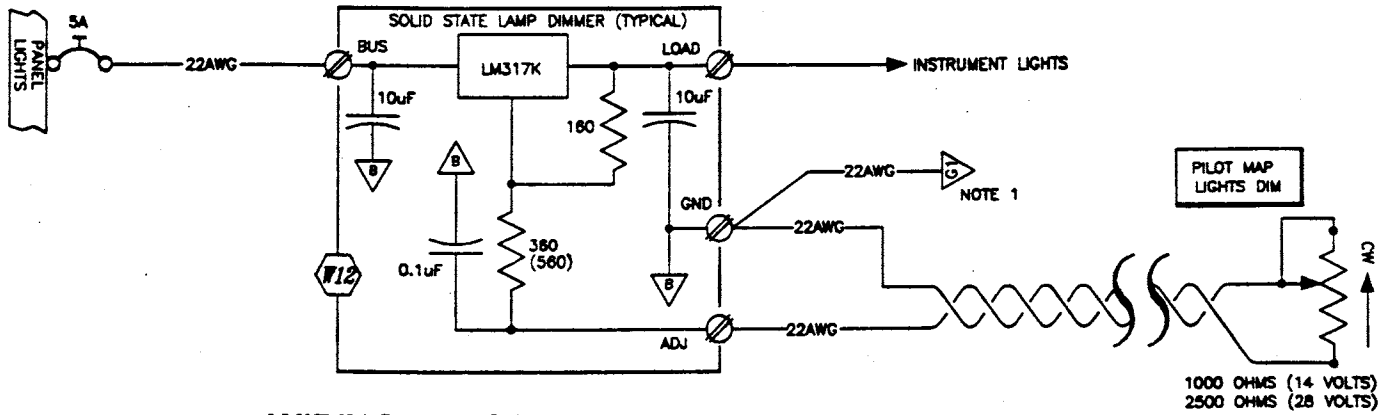

NOTES:

1. WHEN INSTALLED ON METAL AIRCRAFT, MAKE SURE BRACKET IS WELL GROUND TO AIRFRAME. ON COMPOSITE AIRCRAFT, INSTALL GROUND LEAD FROM GROUND LUG TO INSTRUMENT PANEL GROUND BUS.
2. TO TEST FINISHED ASSEMBLY: FIRST TEST WITH OHMMETER TO MAKE SURE THAT INTEGRATED CIRCUIT CASE IS INSULATED FROM BRACKET (INFINITE OHMS). IF INTEGRATED CIRCUIT IS NOT SHORTED TO BRACKET, THEN MAKE TEMPORARY CONNECTION OF POTENTIOMETER BETWEEN GROUND POST [19] AND ADJUST TERMINAL. APPLY +14 VOLTS TO BUS TERMINAL; MINUS GOES TO GROUND POST. MEASURE VOLTAGE BETWEEN GROUND POST AND LOAD TERMINAL WHILE ADJUSTING THE POTENTIOMETER. OUTPUT VOLTAGE SHOULD RANGE FROM ABOUT 4 VOLTS UP TO ABOUT 11 VOLTS AS THE POTENTIOMETER IS VARIED OVER FULL RANGE.
3. 28 VOLT DIMMERS WILL SUBSTITUTE A 560 OHM RESISTOR FOR [7] AND A 2500 OHM POTENTIOMETER. TEST WITH 29 VOLTS APPLIED. ADJUSTMENT RANGE WILL COVER RANGE OF ABOUT 5.8 VOLTS UP TO 25 VOLTS.

TITLE	PAGE
DIMMER KIT ASSY	2.0

